

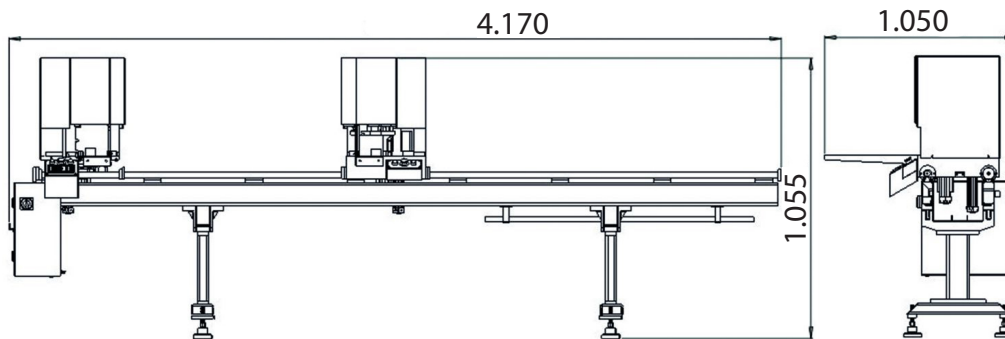

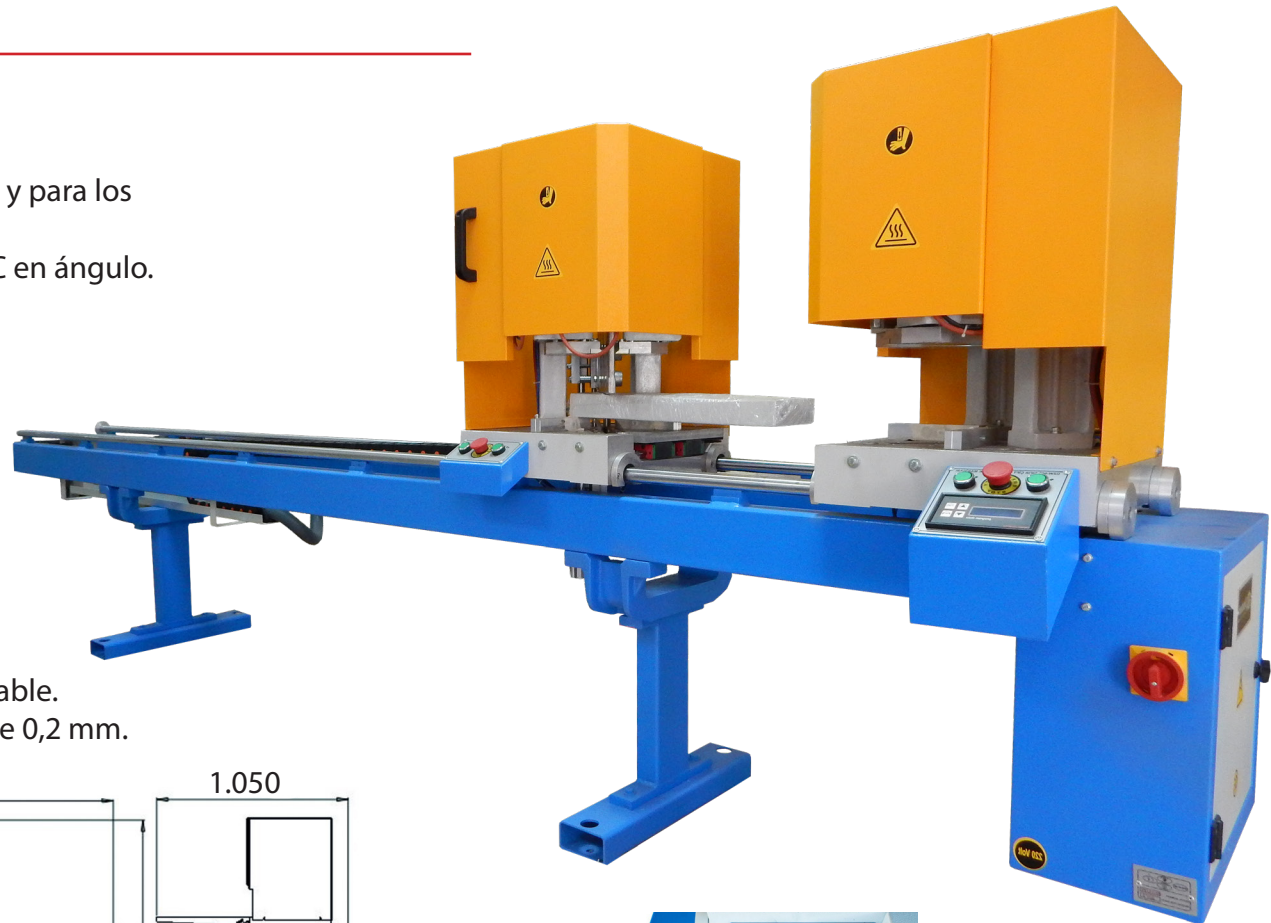



VIRGIN-III

Soldadora doble cabezal - REF : MS2200

CARACTERÍSTICAS

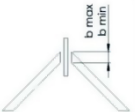
- » Característica de soldadura para perfiles en blanco y para los perfiles con un revestimiento laminado.
- » Para procedimientos de soldado de perfiles de PVC en ángulo.
- » Todos los parámetros se ajustan por separado.
- » Sistema de seguridad con baja presión del aire.
- » Máxima seguridad de funcionamiento.
- » Ángulo de soldadura de 30° a 180°.
- » Tiempo de soldadura sobre 65 segundos.
- » Altura de soldado 180mm (máximo).
- » Molde de sistema reemplazable.
- » Diseño de acuerdo con la CE.
- » Soporte para perfiles largos.
- » Control electro-neumático.
- » Calentador duradero y Teflón fácilmente reemplazable.
- » El espesor de la junta después de la soldadura es de 0,2 mm.

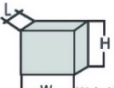
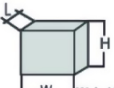

Características técnicas											
		amax	amin	bmax	bmin	xmax	xmin				
	2 x 1.5 KW 230V 50Hz	160 mm	35 mm	170 mm	-	3500 mm	400 mm	6-8 Bar	70 Lt/dak. Lt/min	82x405x150 cm	470 kg

