

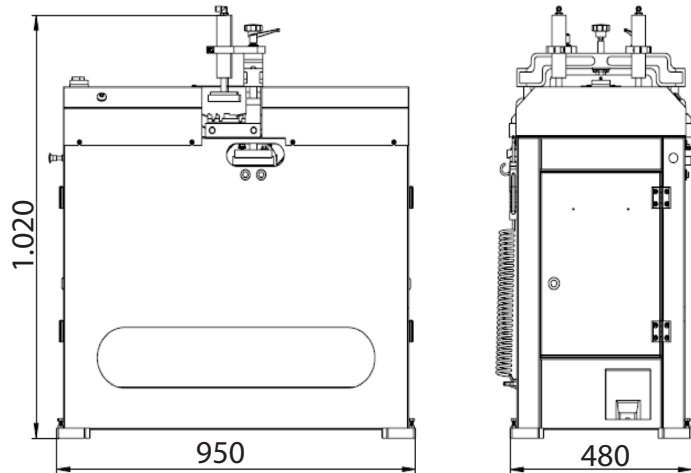





# TASMANIA-II

Junquilladora corte en V - REF : MCJDV

## CARACTERÍSTICAS

- » Corta perfiles de PVC en "V" para soldaduras en "V".
- » Sierra con hoja de diamante, 230mm de diámetro.
- » Sistema de sujeción neumática ajustable.
- » Diseñada en conformidad con la CE.
- » Sistema automático de trabajo.
- » Velocidad de corte ajustable.

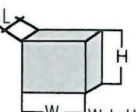

Características técnicas							
				BAR	Hava tüke. Air cons.		
	0,55 KW x 2 400V 50Hz	D=230 mm d=32 mm	3000 D/dak. RPM	6-8 Bar	40 Lt/dak. Lt./min.	45x100x95 cm	102 kg

